

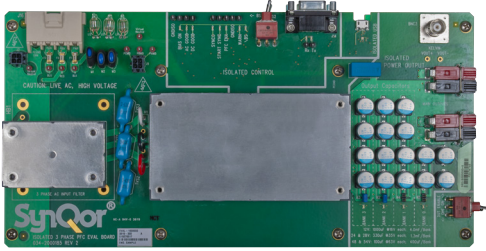

AeroQor 3-Phase Isolated PFC EVAL-KIT

EVAL-KIT for Isolated 3-Phase PFC Converters

Summary



SynQor has developed a group of evaluation board kits to facilitate testing of the isolated 3-Phase PFC converters and the associated AC line filter.

Introduction

This application note is a guide to the features, schematic and Bill of Materials for the following EVAL-KITS:

Table 1. AeroQor EVAL-KITS descriptions

EVAL KIT	AeroQor Isolated 3-Phase Converter	Module Part Number
EVAL-KIT-1000038-01[D]	Isolated 3-Phase AC In to 12 Vdc Out Converter	APFIC-115-3PH-12[R,D]-FT
EVAL-KIT-1000034-01[D]	Isolated 3-Phase AC In to 24 Vdc Out Converter	APFIC-115-3PH-24[R,D]-FT
EVAL-KIT-1000034-02[D]	Isolated 3-Phase AC In to 28 Vdc Out Converter	APFIC-115-3PH-28[R,D]-FT
EVAL-KIT-1000037-01[D]	Isolated 3-Phase AC In to 48 Vdc Out Converter	APFIC-115-3PH-48[R,D]-FT
EVAL-KIT-1000037-02[D]	Isolated 3-Phase AC In to 54 Vdc Out Converter	APFIC-115-3PH-54[R,D]-FT

Note: All EVAL-KITS include the ACF-U-115-3PH-QG 3-Phase filter.

Contents

Section 1 – Converter Description	2
Section 2 – Evaluation Board Block Diagram.....	3
Section 3 – Schematic	4
Section 4 – Component Placement	5
Section 5 – Basic Operating Instructions	11
Section 6 – Paralleling	12
Appendix A – Bill of Materials (BOM)	13

This evaluation board and schematic are intended for demonstration purposes only and no guarantees are made for standards compliance.

Section 1 – Converter Description

The Avionics Isolated PFC (APFIC) Module is a high power, high efficiency AC-DC converter. It operates from a 3-Phase AC input (115 Vrms L-N / 200 Vrms L-L) and generates an isolated DC output. Used in conjunction with a holdup capacitor and SynQor's ACF-U-115-3PH-QG series AC line filter, the APFIC module will draw a nearly perfect sinusoidal current that is in phase with the 3-Phase AC input voltage (PF>0.99).

The 3-Phase Isolated PFC converter has two stages. The input stage takes 3-Phase AC (115 Vrms L-N / 200 Vrms L-L) and shapes and balances the three AC input currents. The PFC module works with any input phase rotation and will startup and operate under any valid load condition. The second stage utilizes a Bus Converter to generate an isolated regulated DC output. A boost converter between the active PFC and the Bus Converter's input supports the output during input line sagging and/or brownout conditions

The term "line-to-neutral (L-N) voltage" is used in this document even though this converter does not utilize a neutral wire. Line-to-neutral references in the document are for information purposes only. If a neutral wire is present in the application, it should not be connected to the evaluation board or PFC.

Thermal Considerations: When testing EMI filters and converters on an evaluation board, be sure to provide adequate cooling. Apply cooling air with a fan blowing across the EMI filter and the converter or across the heatsinks attached to the EMI filter and converter. Monitor the EMI filter and converter temperatures to ensure they don't exceed the maximum rated temperatures shown in the module datasheets.

Shock Warning: There are areas of this evaluation board that have exposed access to hazardous voltage levels. Exercise caution to avoid contact with these high voltage areas. Also note that the evaluation board may temporarily retain high voltage after the input power has been removed. Exercise caution when handling the board or components.

Isolation Warning: The evaluation board contains both isolated and non-isolated circuitry with respect to the AC line inputs on J16. This requires great care in making connections and taking measurements. Exercise caution when making any measurement that makes a connection to an earth ground reference. Use isolated differential probes or clamp on style current probes to avoid ground loop issues. The circuits that are isolated from the AC line inputs can use a regular grounded scope probe to take measurements. The J12 USB serial port, the J14 serial port and the enable switch S1 are all isolated.

Section 2 – Evaluation Board Block Diagram

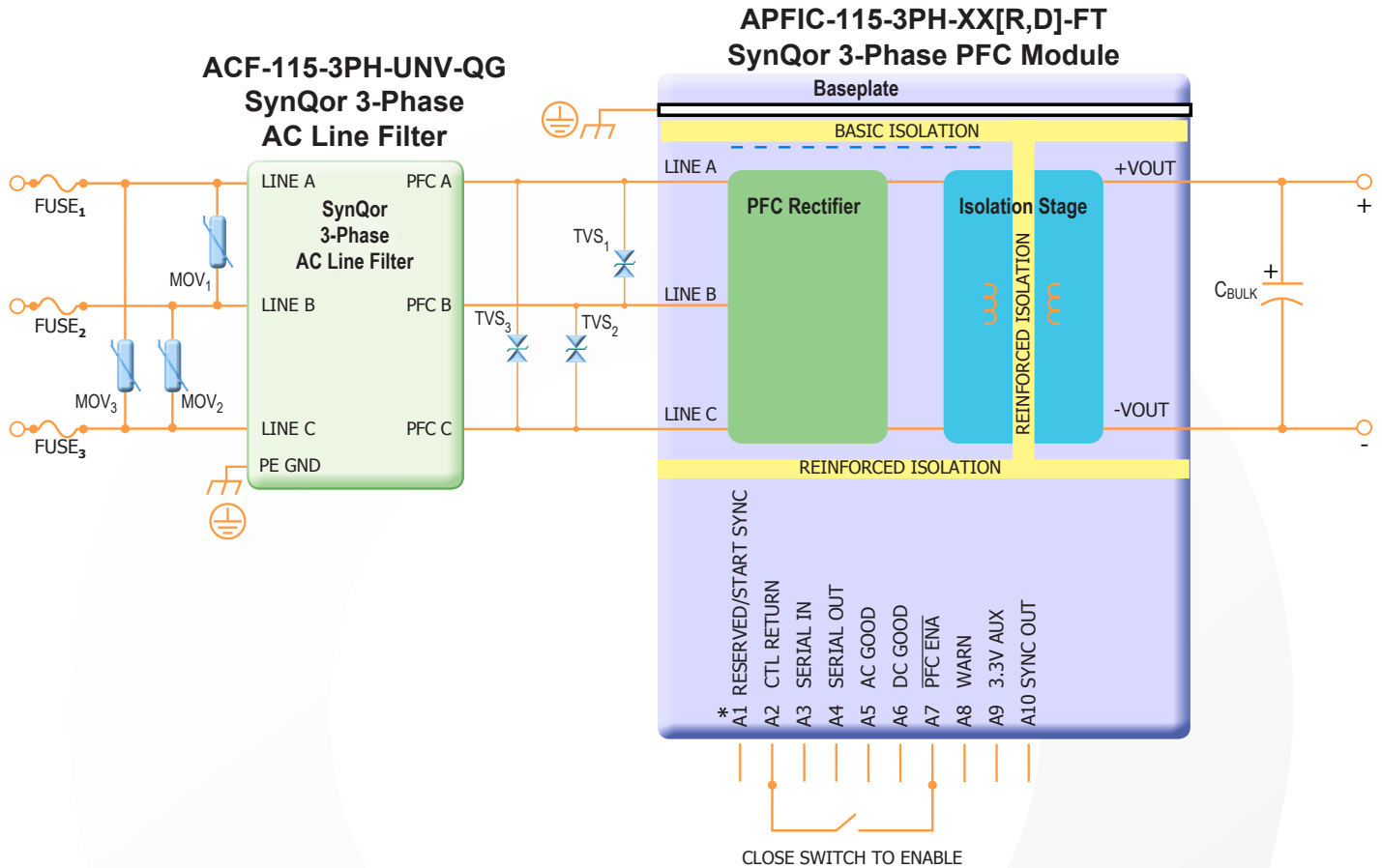

Figure 1: Typical connection diagram for the APFIC-115-3PH-XX[R,D]-FT 3-Phase AC-DC converter.
 * Reserved for Regulated Module START SYNC for Droop Module.

Notes:

Note 1: Additional Hold-Up capacitance across C_{Bulk} may be required for normal operation through interruptions in input power.

Note 2: DC-DC Converters can be used as a load across V_{out} . An Input Stability calculation will need to be performed to ensure proper damping of the system. Typically, C_{Bulk} capacitance and ESR should provide a sufficient damping network across V_{out} ; however, additional capacitor or capacitor with a resistor in series may be required in parallel with C_{Bulk} supplement the input stability damping network for the downstream converters. SynQor’s application notes **“Guidelines for Testing SynQor DC-DC Converters”** and **“Input System Instability”** explain in detail how to configure and test DC-DC converters loads behind a source such as the EVAL-KIT.

Section 3 – Schematic

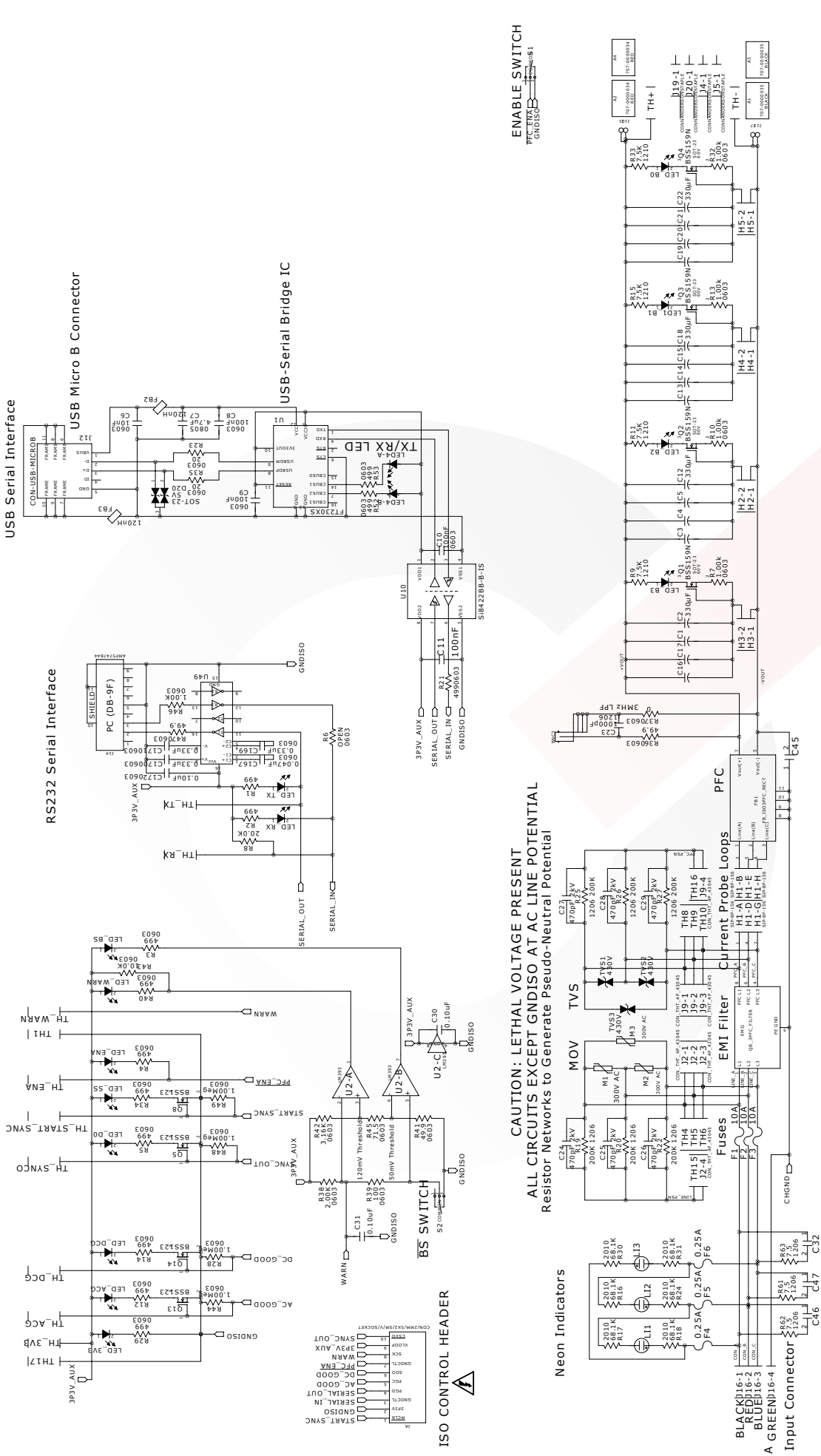

Figure 2. Schematic Diagram for the AeroQor 3-Phase Isolated PFC EVAL-KIT.

Section 4 – Component Placement

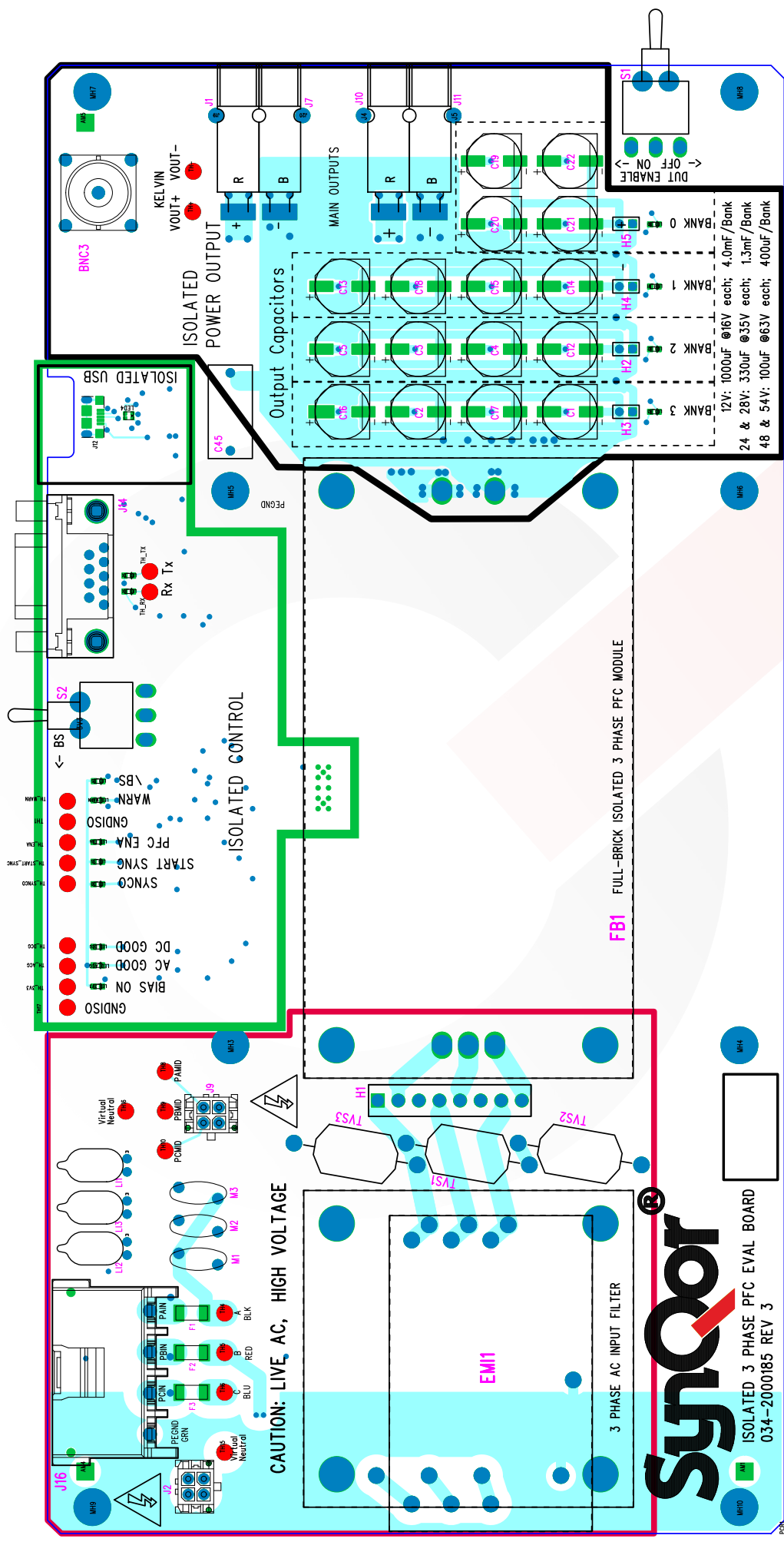

Figure 3. AeroQor 3-Phase Isolated PFC evaluation board component placement (Region 1: Red, Region 2: Green, Region 3: Black).

Region 1: AC Input (Red)

CAUTION: All the signals in Region 1 (Section 4 Red) have LIVE input voltages and are referenced to the AC Input voltage. All the test points in region 1 are in red indicating that differential scope probes must be used when probing these signals, see Figure 3.

Input power is applied through connector J16, see Table 2. Phases A, B, and C are clearly labeled. There is no neutral connection into the board. The different phase rotation (A, B, C) is handled automatically by the APFIC module. Tables 3 and 4 list the fuses, Transient Voltage Suppressors (TVS) and Metal Oxide Varistor (MOV) device specifications along with suggested part numbers.

Table 2: Input Power Connector J16

Connector Terminal #	Signal Name	Part Number
J16-1	AC Line A Input	Hirose Electric Company: DF22-4S-7.92C (28)
J16-2	AC Line B Input	Hirose Electric Company: DF22-4S-7.92C (28)
J16-3	AC Line C Input	Hirose Electric Company: DF22-4S-7.92C (28)
J16-4	Earth Ground	Hirose Electric Company: DF22-4S-7.92C (28)

Table 3: Fuses

Ref Des	Value	Package	Part Number
F1, F2, F3	10 A	2410	Littelfuse, 0451 010.MRL
F4, F5, F6	0.25 A	2410	Littelfuse, 0451 .250MRL

Table 4: TVS and MOV Devices

Ref Des	Value	Package	Part Number
M1, M2, M3	300V AC	Radial, 10mm disc	Metal Oxide Varistor, Epcos, S10K300E2
TVS1, TVS2, TVS3	430V	Through Hole	High Energy Bidirectional TVS, Littelfuse, AK3-430C

Neon Lamp Indicators LI1 – LI3 (Top left hand side of board)

LI1: AC voltage present from Line A to Line B when illuminated.

LI2: AC voltage present from Line B to Line C when illuminated.

LI3: AC voltage present from Line C to Line A when illuminated.

Table 5. Eval board high voltage test points

Reference Designator	Test Point Signal Names	Test Point Color
TH 4	LINE_A / Black	Red
TH 5	LINE_B / Red	Red
TH 6	LINE_C / Blue	Red
TH 15 / TH 16	VIRTUAL NEUTRAL	Red
TH 8	PAM ID	Red
TH 9	PBM ID	Red
TH 10	PCM ID	Red

Note: Test points are red in figure 3 but black on physical unit.

AC Input - Scope Probing Options

- AC Line-Line Input voltages can be monitored with differential scope probes attached between any of the test points labeled A (Black), B (Red) and C (Blue). A resistive averaged Virtual Neutral test point is provided for making L-N measurements.
- AC Input voltages at the PFC module can be monitored with differential scope probes attached between any of the test points labeled PAMID, PBMID and PCMID. A separate Virtual Neutral test point is also provided at the PFC input
- AC Input Phase currents can be monitored by installing current loops in to Header H1 and using an isolated current probe to measure each of the currents.

The evaluation board includes protective MOV devices across all three input lines. These are in place to absorb energy from potential transients that may be present on the AC line. The MOV devices are EPCOS S10K300E2.

Line to Line TVS are included after each filter output pin to clamp the peak voltage seen by the PFC module, when stimulated by an input transient. The TVS devices are Littelfuse AK3-430C or Bourns PTVS-430C-TH

Region 2 Status/Monitor/Control (Green)

All signals in this region (Section 4 Green) are reference to GND ISO – which is fully isolated from both the AC Input and the DC Output regions/signals. The test points here are black – indicating that standard scope probes may be utilized.

There are several different test points on the Status/Monitor/Control section of the evaluation board that can be visually monitored via the LEDs or probed on the adjacent test points as described below.

Table 6. Eval board Signals

LED LABEL	Test Point Signal	Meaning
GNDISO	GNDISO	Reference level for control signals
BIAS ON	3P3V_AUX	DUTs 3v3 Aux Bias Output
AC GOOD	AC_GOOD	DUT's AC_GOOD Output Pin
DC GOOD	DC_GOOD	DUT's DC_GOOD Output Pin
SYNCO	SYNC_OUT	DUT's SYNC OUT Output Pin
START_SYNC	START_SYNC	DUT's START_SYNC I/O Pin
PFC ENA	PFC_ENA	DUT's PFC_ENA Input Pin
WARN	TH_WARN	Lit/High when DUT is warning shutdown
RX	TH_RX	Blinks when characters are being received
TX	TH_TX	Blinks when characters are being transmitted

Control Switches

Enable On/Off Switch

Setting S1 switch to the ON position enables the 3-Phase Isolated PFC converter; setting S1 switch to the OFF position disables the 3-Phase Isolated PFC converter.

Serial Interface Communications

The EVAL-KIT is equipped with an RS-232 serial port and a USB serial interface. By factory default the USB serial interface is enabled for serial communication. If the user would like to enable the RS-232 port, the user will need to remove the red 0603 resistor in figure 4 and add a 499 ohms 0603 resistor at the blue location. Both ports cannot be configured to run simultaneously in the same EVAL-KIT.

Terminal interface has to be configured to these parameters: 9600 baud, 8 data bits, no parity, and one stop bit. Set the terminal emulator to send both a line-feed and a carriage return. The APFIC does not echo any characters sent to the unit. In order to see the characters being sent to the module in your terminal emulator window, enable the echo feature on your terminal emulator. Commands can be sent, and output viewed, with any standard serial terminal emulator.

To communicate with the Evaluation board via USB interface, a USB 2.0 Micro B male cable is needed (Table 7).

Table 7. Suggested USB interface cable

Manufacturer	Part Number	Description
Assmann USB 2.0	AK-300110-018-S	USB 2.0 Micro B male cable

Please refer to application note [SynQor 3-Phase Isolated PFC Terminal Commands](#) for information regarding the communications standards and parameters available for monitoring.

Figure 4: Location of the USB 0603 resistor (Red) and the RS-232 0603 resistor (Blue) on the EVAL-KIT board (backside).

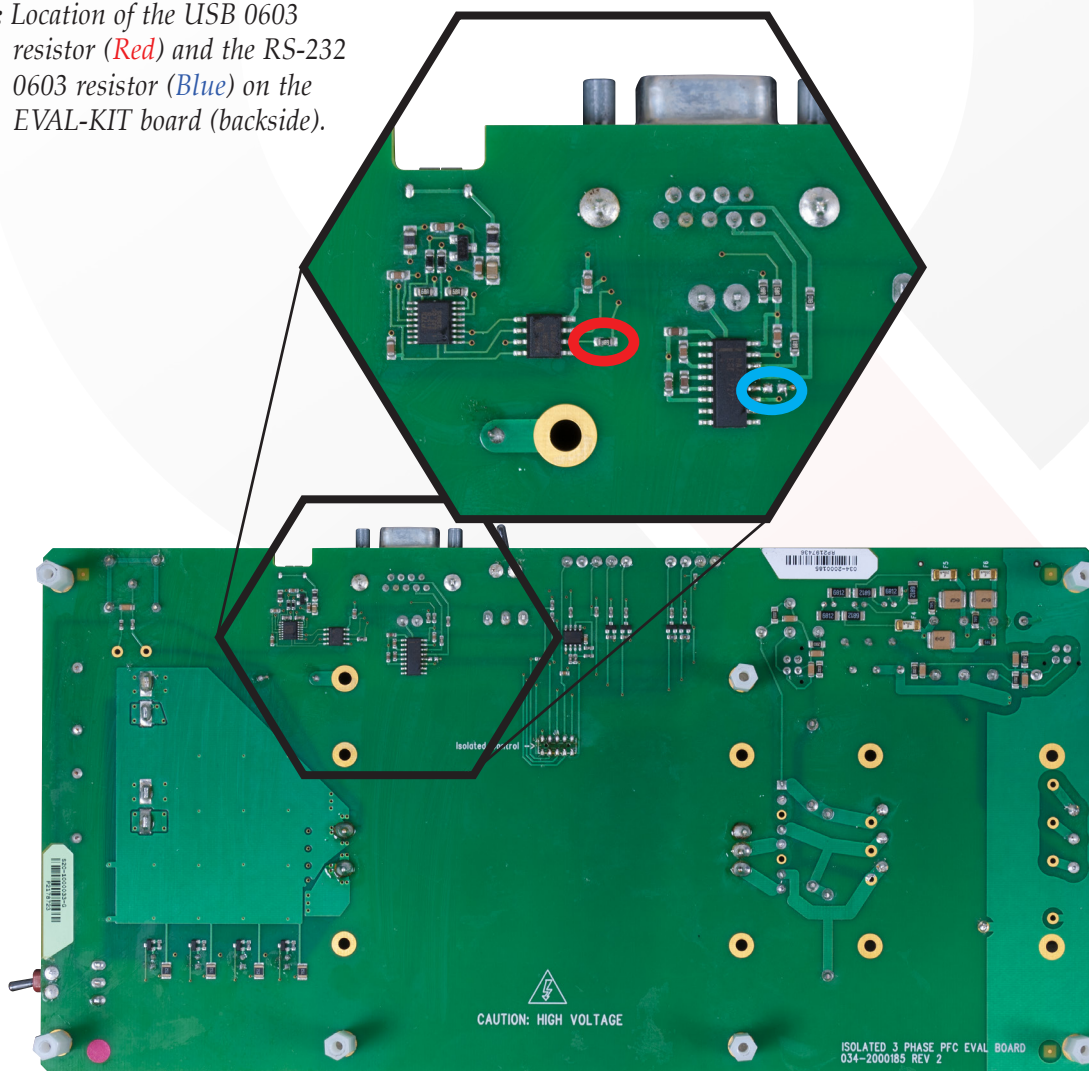

USB Serial Communications Interface

To communicate with the evaluation board kit, the appropriate USB driver must be installed. The FT230XS driver can be found at FTDI chip web site¹.

“Once the USB drivers are properly installed, a new serial port object should become available for application use. Under Windows, the serial port should become visible from the Windows Device Manager, in the “Ports (COM & LPT)” category, and should be assigned a new COMx name (where x is a number, ex: “COM2”). The exact COMx number assigned to the hardware will depend in part on how many COMx based hardware devices have previously been connected to the machine, as each new hardware instance must be assigned a new and unique number to avoid potential conflicts.

If a machine currently has more than one COMx based hardware device attached to the machine, multiple COMx entries (but different numbers, e.g., COM1 and COM2) may exist in the Windows Device Manager “Ports (COM & LPT)” category, and it may not be clear which COMx port number is specifically associated with the FT230X device. If this occurs, the COMx number can be manually identified by temporarily detaching the USB connection to the FT230X while watching the Windows Device Manager to identify which device entry disappears (and subsequently re-appears in the list upon re-attaching the FT230X).

Once the COMx port number assigned to the FT230X is known, any conventional serial port terminal program can be used to open/close/read/write to the COMx port. To communicate with the adaptor board kit, a USB Micro-B Male cable can be used for a direct connection to the USB port.”

RS-232 Serial Communications Interface

To communicate with the evaluation board kit via RS-232, a DB9 Male to RS-232 cable can be used. The DB9 allows for a direct connection from a computer to the eval’s board RS-232 port.

Table 8. Suggested RS-232 interface cable

Manufacturer	Part Number	Description
Assmann WSW Components	AE1324-ND	Cable DB9/25Male

Please refer to application note [SynQor 3-Phase Isolated PFC Terminal Commands](#) for information regarding the communications standards and parameters available for monitoring.

Region 3: DC Output (Black)

All DC voltages on DC output region (Section 4 Black) are referenced to the isolated output of the PFC. The isolated output is delivered to external loads through the MAIN OUTPUT connectors J1/J10 (Vout+) and J7/J11 (Vout-). See Table 9. Mating connectors are provided.

Table 9: Output Power Connectors

Connector Terminal	Signal Name
J1/J10	+VOUT
J7/J11	-VOUT

DC Output - Scope Probing Options.

- BNC3 connector labeled Vout Kelvin provides a Kelvin connection for monitoring Vout during testing.
- The output current can be measured using a standard current probe clamped on to one of the output load lines

¹ Please refer to the FTDI website: <https://www.ftdichip.com>

Capacitor Bank on the Evaluation Board

Because of the different APFIC output voltage options, there are three different types of capacitor banks available, each rated for a specific output voltage. The total capacitance and voltage rating of the capacitor banks depend on the EVAL-KIT part number of the selected board. However, all capacitor banks are composed of solid polymer electrolytic output capacitors. The bank capacitors also have good ESR at low temperature characteristics and a good lifespan at high temperatures. The capacitors are rated for normal operation between the temperatures of -55 °C and 125 °C. Note that the maximum baseplate temperature for the modules is 100°C.

The EVAL-KIT board comes with four user selectable capacitor banks. Each bank can be individually connected (or disconnected) from the DC Output using the two pin jumpers H2, H3, H4 and H5. A LED near each jumper indicates if the capacitor bank is active or not. Note that at least one string of the capacitors must remain connected at all times. A single capacitor bank is usually enough to stabilize the input system for the PFC module and any downstream DC-DC power converters.

Additional output capacitance can be attached through the MAIN OUTPUT terminals. Please refer to the applications section of the [datasheet](#) for more detailed information on additional capacitance to the system.

The available capacitor options for AeroQor are:

Table 10: EVAL-KIT capacitor bank description

EVAL KIT	APFIC Module	Output Voltage	Bank Capacitance
EVAL-KIT-1000038-01[D]	APFIC-115-3PH-12[R,D]-FT	12	4 Banks, 4.0mF per Bank
EVAL-KIT-1000034-01[D]	APFIC-115-3PH-24[R,D]-FT	24	4 Banks, 1.3mF per Bank
EVAL-KIT-1000034-02[D]	APFIC-115-3PH-28[R,D]-FT	28	4 Banks, 1.3mF per Bank
EVAL-KIT-1000037-01[D]	APFIC-115-3PH-48[R,D]-FT	48	4 Banks, 400µF per Bank
EVAL-KIT-1000037-02[D]	APFIC-115-3PH-54[R,D]-FT	54	4 Banks, 400µF per Bank

Section 5 – Basic Operating Instructions

Attach scope probes, desired input voltage and load to the EVAL-KIT :

1. Connect the desired load to the DC Output
2. Apply the 3-Phase input, 115 Vrms (L-N) at J16 on left, using the provided cable assembly. Lamps LI1, LI2, LI3 should light to indicate the presence of hazardous voltages at the input.
3. Use Switch S1 in lower right for PFC enable / disable to turn the unit on and off.

The following figures show the AC current and voltage waveforms that should be observed if the AeroQor 3-Phase Isolated EVAL-KIT has been configured properly. These waveforms were taken using differential voltage probes (L-N) and isolated current probes.

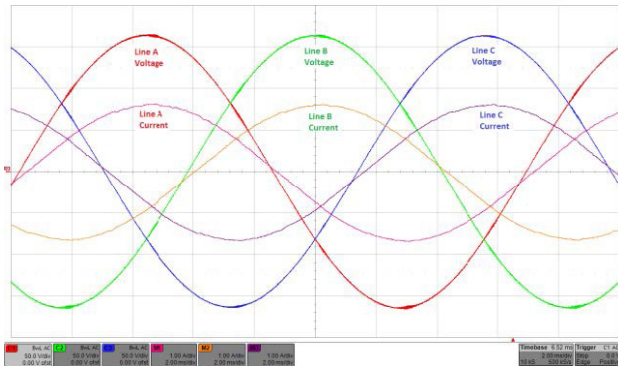

Figure 5. 60Hz, 50% Load, 2 msec/div
Line Voltage: 50 V/div
Line Current 1 A/div



Figure 6. 60Hz, Full Load, 2 msec/div
Line Voltage: 50 V/div
Line Current 2 A/div

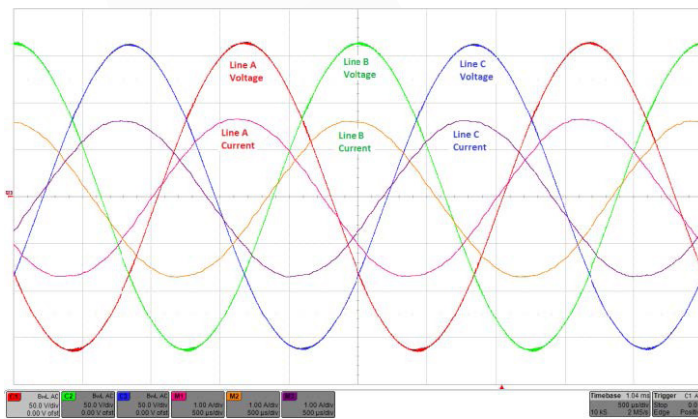

Figure 7. 400Hz, 50% Load, 0.5 msec/div
Line Voltage: 50 V/div
Line Current 1 A/div



Figure 8. 400Hz, Full Load, 0.5 msec/div
Line Voltage: 50 V/div
Line Current 2 A/div

Section 6 – Paralleling

Output Connections

The AeroQor 3-Phase EVAL-KITS have a droop share output option that allows the KITS to be paralleled in order to deliver higher power. To parallel modules in two or more EVAL-KITS, the modules must all be the droop type and have the same output voltage rating. Please choose the EVAL-KITS part number ending with a “D” ex: EVAL-KIT-100003x-0xD. Droop share type “D” boards can be paralleled by simply attaching the output rails, positive with positive and negative with negative (Figure 9). Converters designed for the droop current-share method reduce their output voltage as the output current increases. At lighter loads the output voltage is higher and at heavier loads it is lower. This is graphically represented as output voltage vs. output current, known as a load-line, that slopes downward as current is increased. Converters connected in parallel using the droop share method will share the current in accordance with how well their load-lines are matched. The advantage of this method of paralleling is the ease of implementation since no share bus or serial communication between modules is required. Cable length and impedance should be kept very close between the output terminals of paralleled modules for optimal load sharing.

To synchronize the startup of the output of multiple boards, interconnect the “START_SYNC” test points and the “GNDISO” test points accordingly between boards (Figure 10). Switch “ON” the DUT Enable switch on all boards. Paralleling more than three Eval Boards is not recommended. The differences in output impedance could hinder the load sharing accuracy of the system. For more information regarding the paralleling of 3-Phase Isolated PFC, please refer to the paralleling section on the isolated PFC datasheet.

Input Connections

The input to paralleled AeroQor 3-Phase Isolated EVAL-KITS can be powered from single source or from different sources. The input ground pin of each board should be tied to the ground system of the source that is powering the unit. If the source has a neutral wire, this wire should be left unconnected.

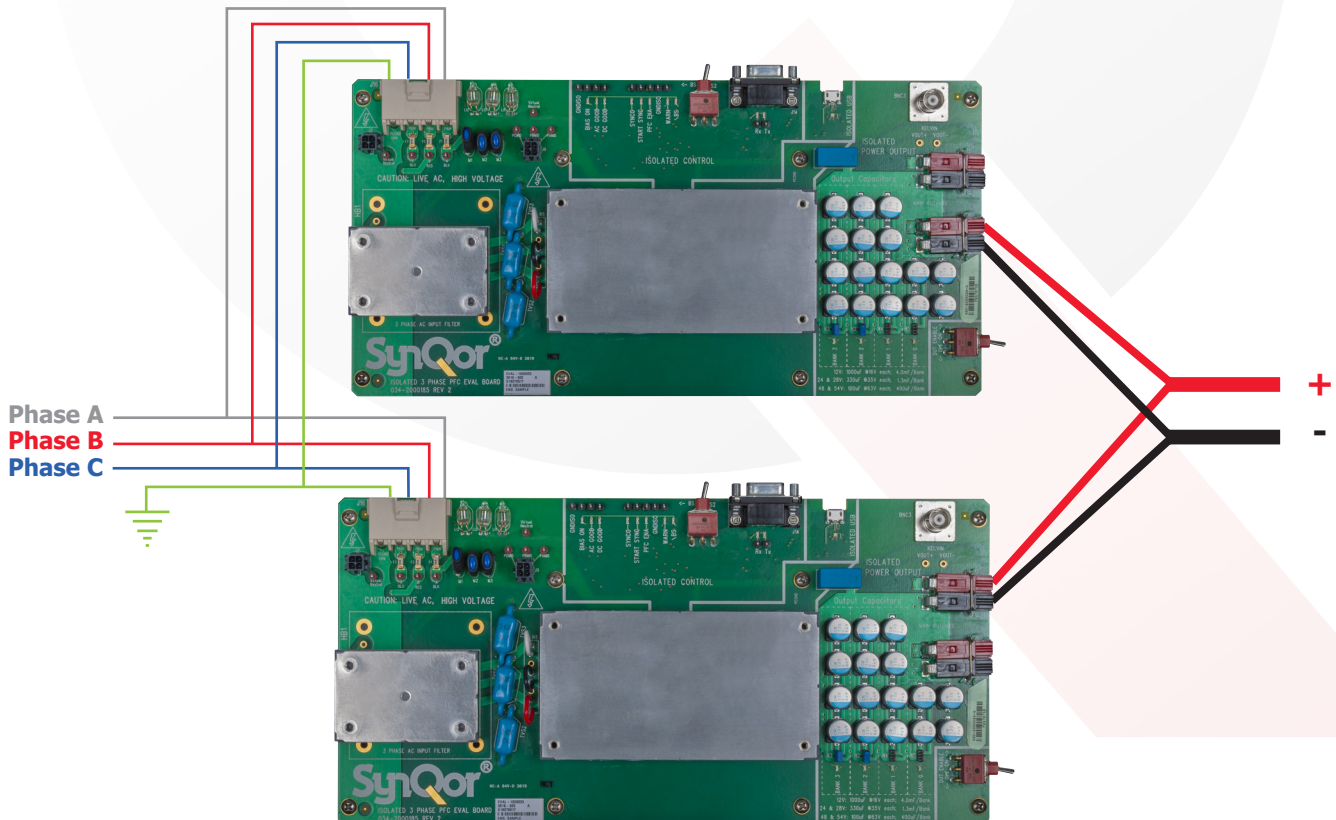

Figure 9. Simplified paralleling diagram of two AeroQor 3-Phase Isolated PFC EVAL-KIT droop share option boards powered from a single source.

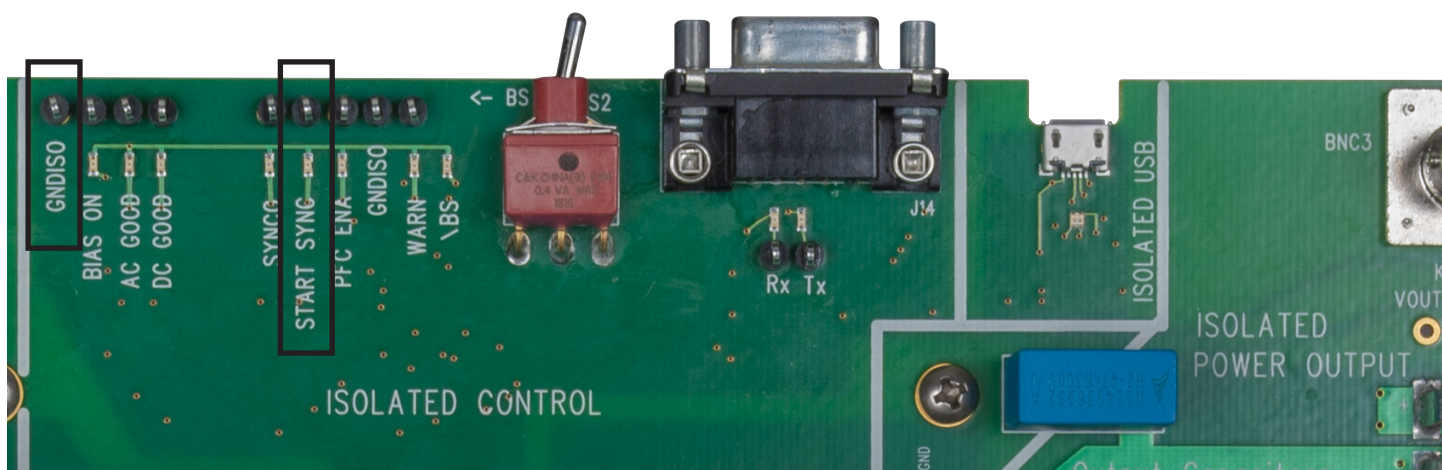

Figure 10. Location of “GNDISO” and “START_SYNC” test points on EVAL-KIT board.

Appendix A – Bill of Materials (BOM)

Table 11: Evaluation board bill of materials.

Ref Des	Value	Package	Description
A1 A3	Black	ANDERSON_HOUSING	Black PP15-45 Anderson Housing
A2 A4	Red	ANDERSON_HOUSING	Red PP15-45 Anderson Housing
C23	1000pF	1206	X7R 2000V
C1 C12 C13 C14 C15 C16 C17 C18 C19 C2 C20 C21 C22 C3 C4 C5	100uF	Radial, Can - SMD	Solid Polymer Electrolytic SMT
C10 C11 C8 C9	100nF	0603	X7R 25V
C6	10nF	0603	X7R 50V
C30 C31	0.10uF	0603	X7R, 50v
C172	0.10uF	0603	X7R 16V
C32 C46 C47	4700pF	2220	X7R, 250VAC, 4700pF, 2220

Ref Des	Value	Package	Description
C24 C25 C26 C27 C28 C29	470pF	1206	X7R 2KV
C7	4.7uF	0805	X7R 16V
C167	0.047uF	0603	X7R 16V
C169 C170 C171	0.33uF	0603	X7R, 16V
C45	OPEN		Capacitor, Polypropylene Film, 300v AC, Y2, 47nF, 20%, 18x8.5mm
D20	5V	SOT-23	TVS Double BIDI ESD Protection Diodes, 5V, SOT-23
F1 F2 F3	10A	2410	10A Fuse
F4 F5 F6	0.25A	2410	Fuse, .25A 2410
FB2 FB3	120nH	0805	120nH, 25%, 0805 Ferrite Bead
FB1	OPEN		
J12		USB MICRO B	USB Micro-B Female SMT Receptacle
M1 M2 M3	300V AC	Radial	Metal Oxide Varistor, 300V AC, 10mm disc
Q5 Q8 Q13 Q14	100V	SOT-23	N-Channel Mosfet, 100V
Q1 Q2 Q3 Q4	60V	SOT-23	N D-FET, 60V, SOT-23, 8 Ohms
R28 R44 R48 R49	1.00Meg	0603	Resistor
R19 R20 R22 R25 R26 R27	200K	1206	Resistor, High Voltage
R16 R17 R18 R24 R30 R31	68.1K	2010	Resistor

Ref Des	Value	Package	Description
R8	20.0K	0603	Resistor
R43	10.0K	0603	Resistor
R11 R15 R33 R9	7.5K	1210	Resistor
R42	3.16K	0603	Resistor
R38	2.00K	0603	Resistor
R10 R13 R32 R46 R7	1.00k	0603	Resistor
R12 R14 R2 R21 R29 R3 R34 R4 R40 R5 R52 R53	499	0603	Resistor
R39	100	0603	Resistor
R45	71.5	0603	Resistor
R36 R41 R47 R1	49.9	0603	Resistor
R23 R35	20	0603	Resistor
R61 R62 R63	7.5	1206	CRCWHP Series-Pulse proof, high power
R37	0	0603	Resistor
R6	OPEN	0603	Resistor
TVS1 TVS2 TVS3	430V		High Energy Bidirectional TVS
S1 S2	OPEN		SPDT-T series Subminiature toggle switch
U1		SSOP-16	USB-UART Bridge by FTDI
U10		SO-8	Dual-Channel Digital Isolator, SO-8, Bi-Directional, 150Mbps, Safety Rated
U2		SO-8	DUAL COMPARATOR
U49		SO-16	RS-232